

The VK Powermate supplies 13.8V DC at currents of up to 10 amps.

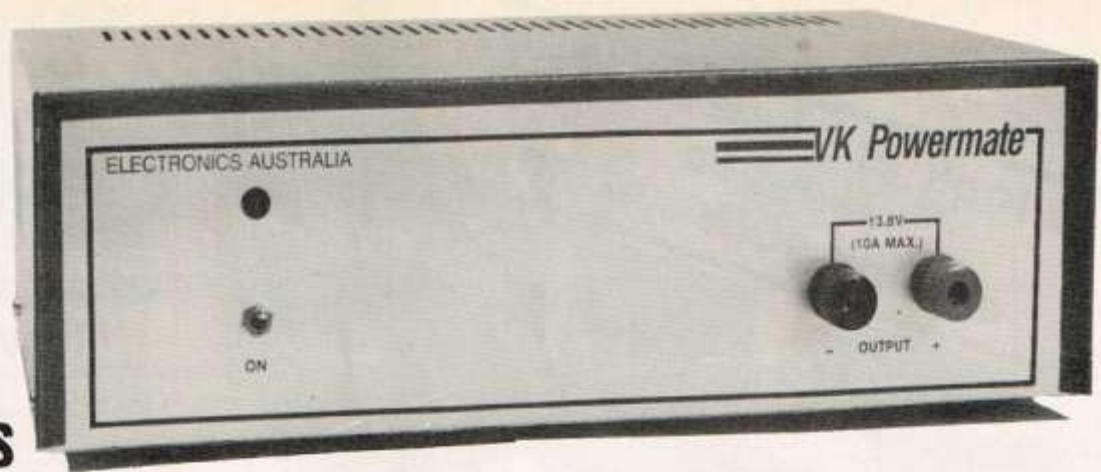

Build this 13.8V supply and retire that messy battery

VK Powermate

by COLIN DAWSON

One of the most consistently requested projects would have to be a regulated 12V power supply to run amateur band transceivers. Five years ago we presented the VK Powermate to satisfy this demand. Now, following in its footsteps, comes the Powermate Mk II — able to deliver more than 8A and using only a few extra components.

Typical amateur equipment likely to need a power supply such as described here would be higher output — 25 to 30 watt — two-metre transceivers, or one of

the lower output — 10 watt — models driving an "afterburner" (RF power amplifier) possibly designed to deliver 40 to 50 watts. This latter arrangement can

be particularly demanding.

Faced with the need to power such equipment, many an amateur resorts to a 12V battery discarded from the family car, connected across some form of "trickle" charger. There are a number of disadvantages to this method. The battery requires periodic maintenance, poses a hazard to other equipment by virtue of its acid electrolyte, has a limited life expectancy, and will not maintain an output of 13.8V under load. There is also a very real risk of introducing significant hum into the signal — and being chipped

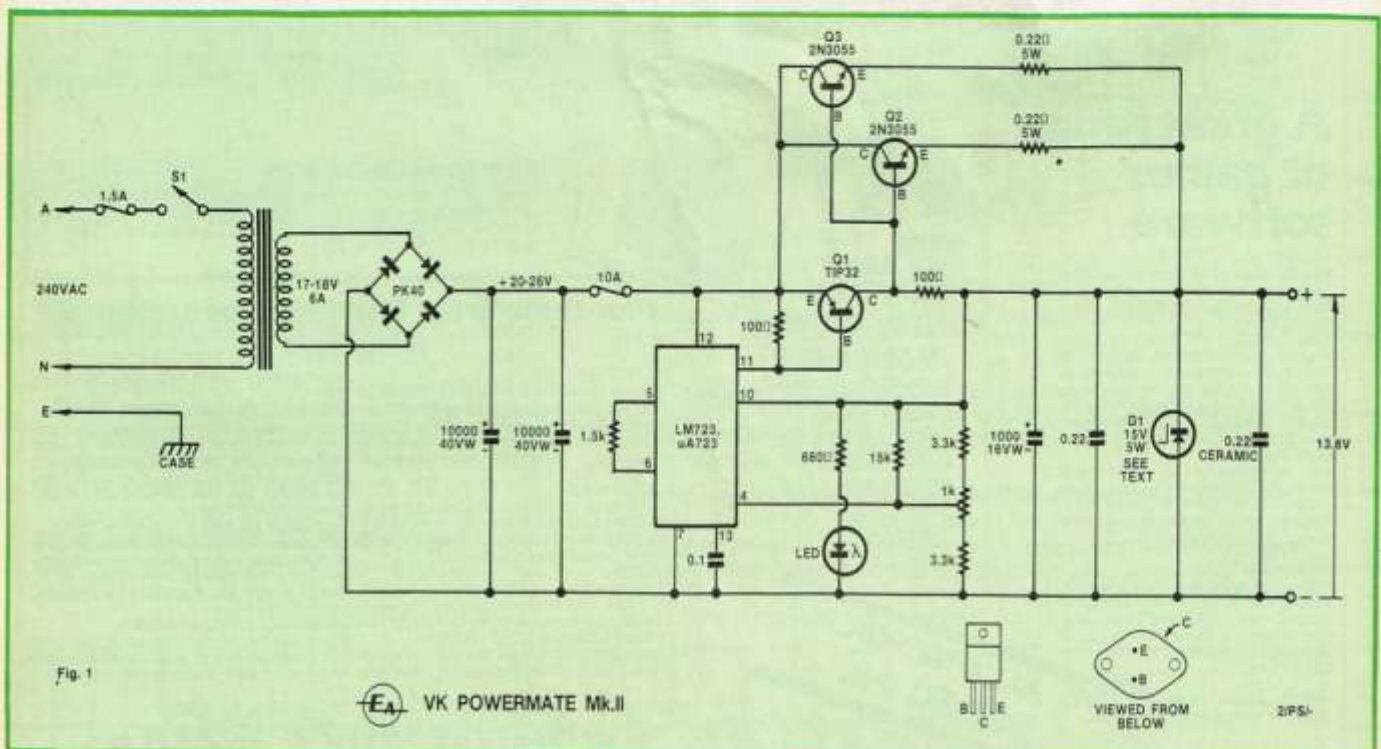

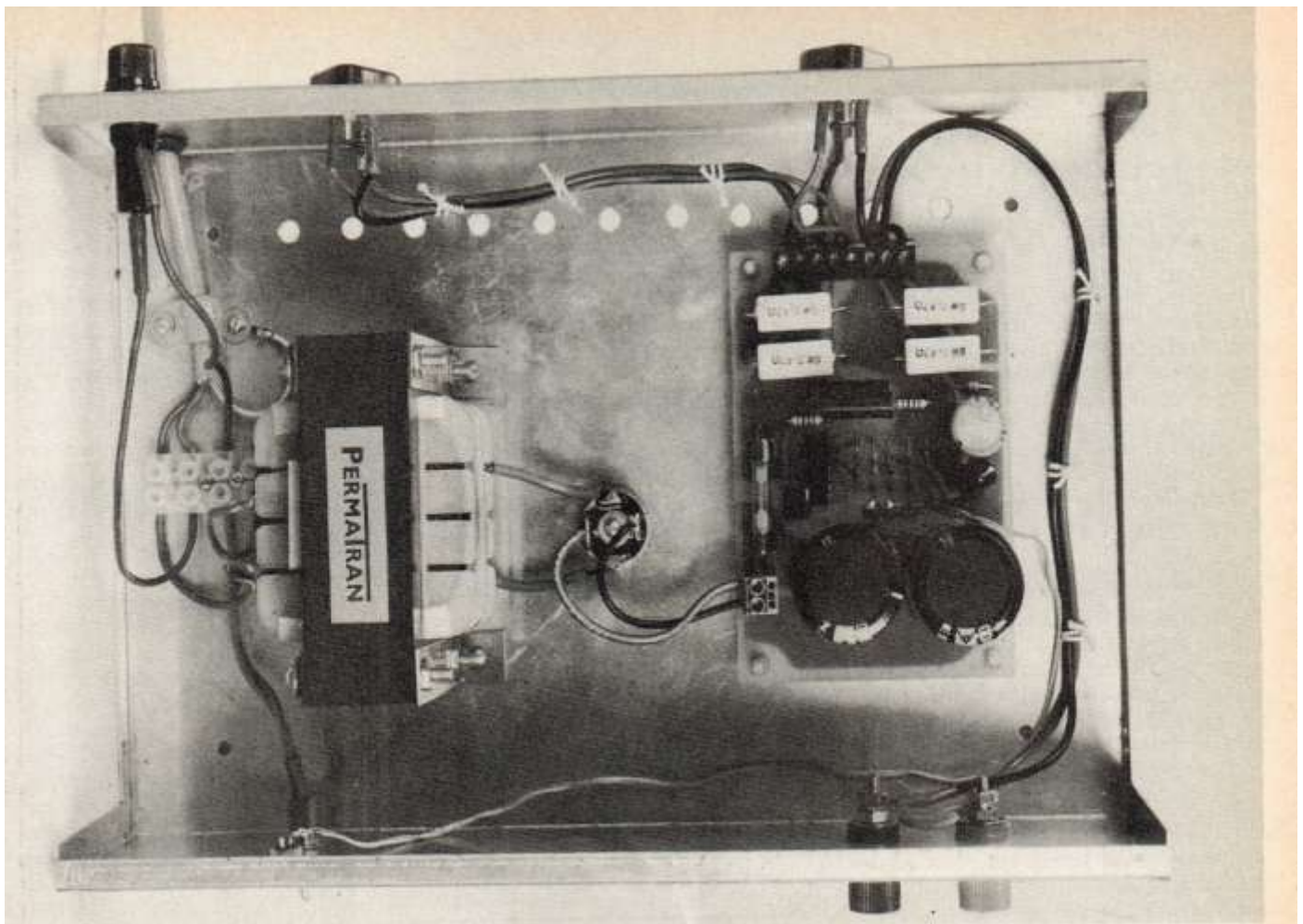

View inside the prototype. Note the row of holes drilled in the chassis to promote air flow.

about it by one's fellow amateurs! This project overcomes those problems.

A voltage of 13.8V is now a well established design figure, the majority of transceivers being rated to give maximum RF output at this figure. Originally, transceivers of this type were designed primarily for use in cars where a nominal 12V supply is available from the battery.

However, since the electrical system in a car normally runs at between 13 and 14 volts, the transceiver manufacturers long ago decided to rate all their equipment for about 13.8V. This enables considerably more power to be achieved, as much as 20% more, than

would be available if the rating was exactly 12V.

Design details

This design is an upgraded version of the May 1978 unit, the main aim being greater current capability. The previous design had a current limit of about 5A continuous, the main limiting factor being the 2N3055 output transistor.

In this version we have duplicated the output stage, ie, two 2N3055s in parallel, providing up to twice the current rating with suitable heatsinking. But that is not the same as saying that we automatically get 10A out of the system. Other factors now limit the current rating.

One is the transformer. This is the same model as used in the original, and has a continuous rating of 6A, so this must be regarded as the maximum continuous rating. But the transformer can deliver more on an intermittent basis – such as when used in an amateur role – and it should be quite practical to run it up to about 8.5A under typical 50% duty cycle conditions.

If it was desired to run 8.5A continuously, two changes would have to be made: a transformer with at least this continuous rating and more substantial heatsinking, such as moderately large finned heatsinks, for the output transistors.

Beyond 8.5A, even assuming the above modifications, the circuit will cease to regulate, due mainly to the limitations of the power transformer, rectifier, and filters, and their inability to maintain enough input voltage to overcome the losses in the rest of the system. Thus the output voltage would fall, though not significantly up to about 10A. But this must be regarded as the absolute maximum for this circuit.

As already implied, we can avoid the need for "add-on" heatsinks for current up to about 6A continuous. The metal K&W case has a large enough surface area to dissipate most of the heat generated by the output transistors. The ventilated cabinet also allows heat from

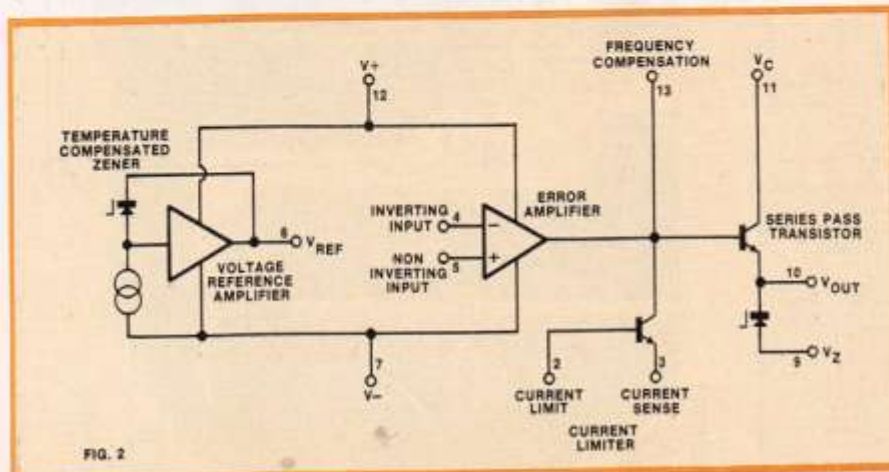

FIG. 2

regulator. The latter figure shows the 723 regulator as comprising a series pass transistor, error amplifier and reference voltage source. The error amplifier compares a proportion of the output voltage with the internal reference voltage source and makes continual adjustment to the base current of the series pass transistor.

Low dropout voltage

Maximum current rating of the series pass transistor in the 723 regulator is 150mA. This must be amplified by external power transistors to provide a supply capable of several amps. In this circuit the series pass transistor is used to drive a PNP power transistor (TIP32) which in turn provides current drive to two NPN power transistors (2N3055).

This arrangement has a low dropout of about 3V, which is equal to that of the 723 when used alone. Consequently, this circuit has very good line regulation without having excessive power dissipation.

The TIP32 transistor has a 100Ω resistor connected between its base and emitter, and the two 2N3055s have similar resistors connected between their base and emitter circuits, though not directly to their emitters, which are isolated by the 0.22Ω resistors. These 100Ω resistors avoid the possibility of high temperature leakage degrading the regulation

characteristic of the power supply.

A problem which can arise through using parallel output transistors — as we have done — is unequal load sharing. Due to slightly differing characteristics, one transistor may tend to conduct more heavily than the other. This is prevented by the inclusion of current sharing resistors in the emitter circuit of each transistor, which forces the transistors to accept an equal share of the load.

Alternative resistors

The value of these resistors is given as 0.22Ω, but we realise there may be some difficulty in obtaining these in the 5W range. For this reason we have designed a printed circuit board which will accept two parallel 5W resistors in each position. This would allow 0.47Ω resistors to be used and these are in plentiful supply.

A 1.5kΩ resistor is connected between pins 5 and 6 of the 723. This is included to make the source impedance feeding the non-inverting input of the error amplifier approximately equal to the source impedance of the output voltage divider which drives the inverting input. Adding this single component makes quite a worthwhile improvement to the temperature stability of the output voltage.

The output of the regulator is heavily

bypassed to give a low output impedance at radio frequencies and to ensure good transient response.

A crude but effective method of over-voltage protection is used in this circuit. It consists of a zener diode, of appropriate voltage rating, and 5W or higher power rating, wired directly across the output terminals. If, for any reason, the regulator circuit malfunctions and the output voltage tends to rise above the selected voltage, the zener will draw very heavy current and blow the 10 amp fuse.

The zener voltage selected will depend on the tolerance of the transceiver or other equipment to excessive voltage. Most service manuals specify an absolute maximum voltage, typically 15 for a nominal 13.8V unit. Thus a 15V zener would be appropriate.

In blowing the fuse the zener itself will most probably be sacrificed, but this is a small price to pay in order to protect a valuable piece of equipment. There are more elegant methods of protecting transceivers against over-voltage, but this method is simple and reliable.

Construction

Most of the circuit components are mounted on the printed circuit board (PCB) which is coded 83ps12 and measures 82 x 119mm. Dominating the PCB are the two 10,000μF/40V electrolytics (Elna) which have a combined ripple rating of 10.4A at 120Hz. Substitution of smaller electrolytics is not really recommended as their lower ripple ratings may lead to reduced service life.

Do not substitute a less rugged transistor for the TIP32, which has a collector current rating of 4 amps. Other transistors (such as 2N3053 or BD140) will work, but on overloads they will "punch through" before the 10 amp fuse blows. And if that happens, the 723 IC will blow too.

A small flag heatsink should be fitted to the TIP32. This can be either a commercial unit or a piece of light gauge aluminium about 20 x 30mm.

Do not try to increase the output rating of the Powermate by increasing the fuse rating. This will only lead to the possibility of damage to the 3055s, and quite possibly to other parts of the

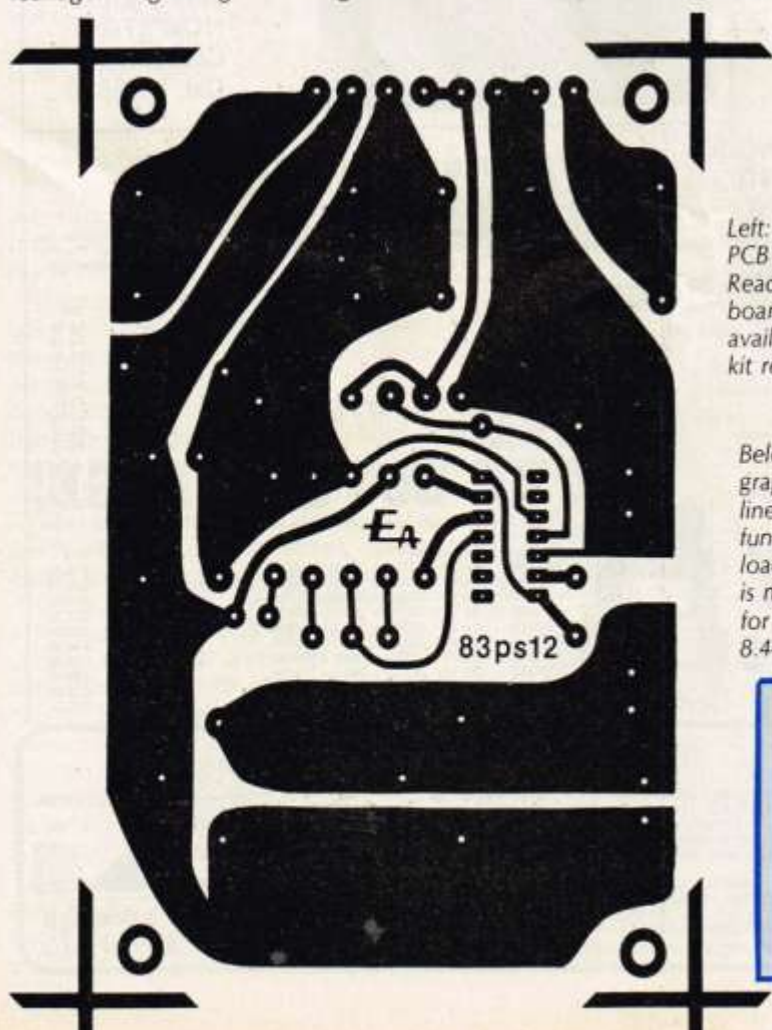

Left: actual size PCB artwork. Ready etched boards are available from kit retailers.

Below: this graph plots the line output as a function of load. Regulation is maintained for loads up to 8.44A.

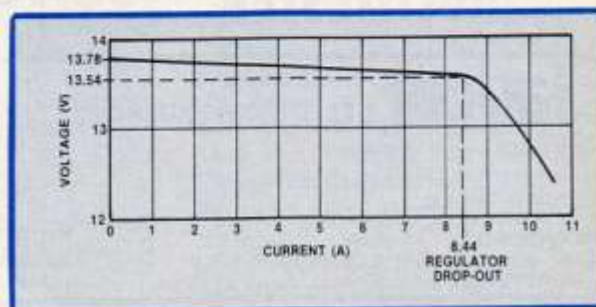

VK Powermate

circuit. The specified 10A fuse will take surges of up to 14A before it blows, which is well above the regulator drop out current.

At 305 x 205 x 90mm, the K&W case can easily accommodate all the components and allows some free space for cooling. Between the transistors, bridge rectifier, transformer and power resistors, there is a lot of heat generated when the supply is working hard. In addition to the slotted lid, we would recommend drilling a series of holes across the bottom of the chassis to promote air flow.

If the planned use of the power supply suggests that additional heatsinks should be fitted, there are a number of types available. Two small heatsinks will probably be a more convenient arrangement than one large one and two types listed in the Dick Smith catalog would seem to be suitable. One is listed as H-3422 and the other, slightly larger, as H-3460. They should be mounted with the fins vertical.

The transformer used is known as the "M2000" and has a rating of 18VAC at 6A (ours was supplied by Jaycar, but other kit sellers have an equivalent). Virtually any transformer with a secondary voltage of 17 to 18V at a current of 6A is suitable. Lower current ratings could be used if the inferior load regulation is acceptable.

In the other direction there is at least one transformer available with an 8A rating. This is the model JT 266, made by Jones Transformers Pty Ltd, and available from Ace Radio, 136 Victoria Rd, Marrickville, NSW.

When mounting the output transistors, use a mica washer, two insulating bushes and heatsink compound. Most of these are available in TO-3 mounting kits. The connection to the collectors of these transistors is made by means of solder lugs to one of the mounting screws for each transistor (the case is the collector for this type of transistor). Later, when the Powermate has been tested, plastic covers should be fitted to the 3055s.

An EDI Minibridge, type PK40F, is used as the bridge rectifier. It has an average current rating of 8 amps. As with the transistors, the PK40 heatsinks to the chassis, but no mica washer need be used here — the metal face of the rectifier is not an electrical connection. Alternatively, the bridge rectifier could be the higher rated PB40 which is widely available.

A pair of binding post/jack sockets are used for the output connections. Don't forget to use heavy duty insulated wire for all the high current wiring. The type

known as "4mm auto cable" is suitable.

The 0.22 μ F ceramic capacitor is connected across the back of the output terminals. This provides RF bypassing of the output. The negative output terminal may also be connected to the case to minimise the effects of radiated RF signals. This could be a consideration when the antenna of high power equipment is very close to the power supply, although we were not able to

induce any anomalies with the antenna of a 2-metre set only a metre away.

Take care with the mains wiring. The three-core mains cord should be passed through a grommetted hole in the rear of the case and anchored with a cord clamp. Mechanically terminate and solder the earth wire to a solder lug secured under one of the transformer mounting screws. The rest of the circuit is not earthed.

Terminate the active and neutral conductors plus the wires to the transformer primary and the mains switch to a three-way insulated terminal block. Make sure that the soldered connections to the mains switch and transformer primary fuse are insulated with heatshrink tubing or "spaghetti".

When construction is complete, check all wiring carefully. To protect the over-voltage zener diode, it is important that the 1k Ω trimpot be set initially for minimum output voltage. This is with the wiper closest to the positive rail or, in physical terms, fully anticlockwise as seen from the rear of the case.

Test the supply with a dummy load before it is used with a transceiver. A piece of jug element cut to a length would be suitable. Make sure that the output voltage does not change by more than 200mV between the loaded and unloaded conditions. This is a far more valid test than operating the power supply with a transceiver because your voltmeter is quite likely to be upset by the transmitted signal.

In this regard, analog meters are likely to be less affected than their digital counterparts. We found a digital meter to have an error of 1V during transmit, a cheap analog to have an error of 0.5V and an expensive analog to have no error. To test whether an indicated change in voltage is genuine, short the test leads of the meter together and transmit. Obviously, any reading on the meter is an induced error — but don't be surprised if this does happen.

(Note that the suggested dummy load will get very hot, and may even burn out, if used for more than a few seconds at a time. This should be long enough to set the voltage but, if prolonged testing is necessary, it would be necessary to immerse it in water.)

During normal operation, the output transistors will become quite hot, especially if the supply is running at 6A continuously. This is quite normal. All components are within ratings.

So there it is; a rugged power supply with excellent filtering and regulation which should be large enough for all but the very large transceivers. It would also serve as a bench supply for any service organisation handling car radios and similar equipment. It should have a long and useful life. 

PARTS LIST

- 1 K&W case, 306 x 204 x 90mm or similar metal project case.
- 1 Scotchcal front panel, 305 x 90mm
- 1 PCB, 82 x 119mm, code 83ps12
- 1 transformer with secondary 17 to 18V at 6A
- 1 SPST mains toggle switch
- 1 4-way insulated mains terminal block
- 1 2-way PC-mounting terminal block
- 1 8-way PC-mounting terminal block
- 2 heavy-duty binding posts, 1 red, 1 black
- 1 3AG panel mounting bayonet fuse holder and 1.5A fuse
- 2 fuse clips, Swann FC1
- 1 3AG 10A fuse
- 2 solder lugs
- 1 flag heatsink (for TIP32)

SEMICONDUCTORS

- 1 LM723 or μ A723 IC regulator
- 1 TIP32 PNP transistor
- 2 2N3055 NPN transistors
- 1 PK40 or equivalent bridge rectifier
- 1 15V 5W zener diode
- 1 LED and bezel

CAPACITORS

- 2 10,000 μ F/40V electrolytic (PCB mounting)
- 1 1000 μ F/16V electrolytic (PCB mounting)
- 1 0.22 μ F ceramic
- 1 0.22 μ F metallised polyester (greencap)
- 1 0.1 μ F greencap

RESISTORS (1/4W, 5%)

- 1 x 15k Ω , 2 x 3.3k Ω , 1 x 1.5k Ω , 1 x 680 Ω , 2 x 100 Ω , 2 x 0.22 Ω /5W (see text), 1 x 1k Ω trimpot (large vertical)

MISCELLANEOUS

- 4 rubber feet, 4 nylon PCB stand offs, 1 grommet, mounting hardware for TO-3 transistor, heatsink compound, 2 TO-3 plastic covers, mains cord and three-pin plug, mains cord clamp, heatshrink tubing, 4mm auto cable, hook-up wire, screws, nuts, lockwashers, solder.

NOTE: Component substitutions are not recommended. See text.