

Crystal Oscillator Circuits – Page 1

Radio receivers and transmitters both require a precise frequency reference, and this reference was until recently almost always provided by a crystal oscillator. A crystal oscillator is an electronic circuit that uses the mechanical resonance of a vibrating crystal to generate a sinusoidal electronic signal at a very precise frequency. The translation by certain materials of a mechanical impulse to an electrical oscillation is called the piezoelectric effect. The most common type of piezoelectric resonator until recently was the quartz crystal and electronic circuits designed around them are called crystal oscillators.

Piezoelectricity was discovered by Jacques and Pierre Curie in 1880. The first crystal-controlled oscillator was constructed at Bell Laboratories in 1917 by Alexander Nicholson using a crystal of Rochelle salt. Walter Cady, a professor at Wesleyan University, built the first quartz crystal oscillator in 1921. By 1926, quartz crystals were used to control the frequency of AM radio broadcast transmitters and were widely used by amateur radio operators.

In crystal oscillators, the usual electrical resonant circuit is replaced by a mechanically vibrating crystal. The crystal (usually quartz) has a high degree of stability in holding constant at whatever frequency the crystal is originally cut to operate. The crystal oscillators are, therefore, used whenever great stability is needed, for example, in communication transmitters, and receivers, digital clocks etc.

The Piezo-electric effect is when a mechanical pressure is applied across the faces of the crystal, a voltage proportional to the applied mechanical pressure appears across the crystal. Conversely, when a voltage is applied across the crystal surfaces, the crystal is distorted by an amount proportional to the applied voltage. An alternating voltage applied to a crystal causes it to vibrate at its natural frequency.

Besides quartz, the other substances that exhibit the Piezo-electric effect are Rochelle salt and Tourmaline. Rochelle salt exhibits the greatest piezoelectric effect, but its applications are limited to manufacture of microphones, headsets and loudspeakers. It is because the Rochelle salt is mechanically the weakest and strongly affected by moisture and heat.

Tourmaline is most rugged but shows the least Piezo-electric effect. Quartz is a compromise between the piezoelectric effect of Rochelle salt and the mechanical strength of tourmaline. It is inexpensive and readily available in nature. It is mainly the quartz crystal that is used in radio frequency oscillators.

Equivalent circuit of a quartz crystal resonator

To analyse the electrical response of a quartz crystal resonator, it is very often useful to depict it as the equivalent electrical components that would be needed to replace it. This equivalent circuit can then be used to analyse its response and predict its performance as in the diagram below:

Crystal Oscillator Circuits – Page 2

The equivalent circuit given below is often called the 4-parameter crystal model and it is sufficient for many calculations and to illustrate the operation of the crystal.

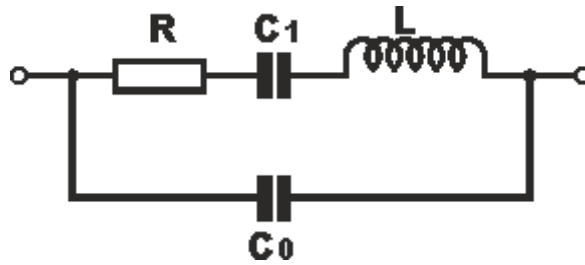

Fig b - Quartz crystal theoretical equivalent circuit

It is possible to equate these theoretical constituent components to real physical attributes of the crystal:

- **L:** The inductance arises from the mass of the material.
- **C1:** This capacitance arises from the compliance of the crystal.
- **R:** This element arises from the losses in the system. The largest of these arises from the frictional losses of the mechanical vibration of the crystal.
- **C₀:** This capacitance in the theoretical quartz crystal equivalent circuit arises from the capacitance between the electrodes of the crystal element. This is often referred to as the shunt capacitance.

Apart from their use in oscillators, quartz crystals find uses in filters. Here they offer levels of performance that cannot be achieved by other forms of filter. Often several crystals may be used in one filter to provide the correct shape. The picture below show a home made band pass crystal ladder filter.



For use in electronic oscillators, the crystal is suitably cut and then mounted between two metal plates, as shown in this old FT-243 example. You can just make out the actual Quartz between the two metal plates. The copper plates in the Bakelite housing connect to the connection pins, then there is a sandwich of a metal plate, the actual crystal, another metal plate, a spring and lastly the insulating plate that keeps the assembly from touching the metal cover.

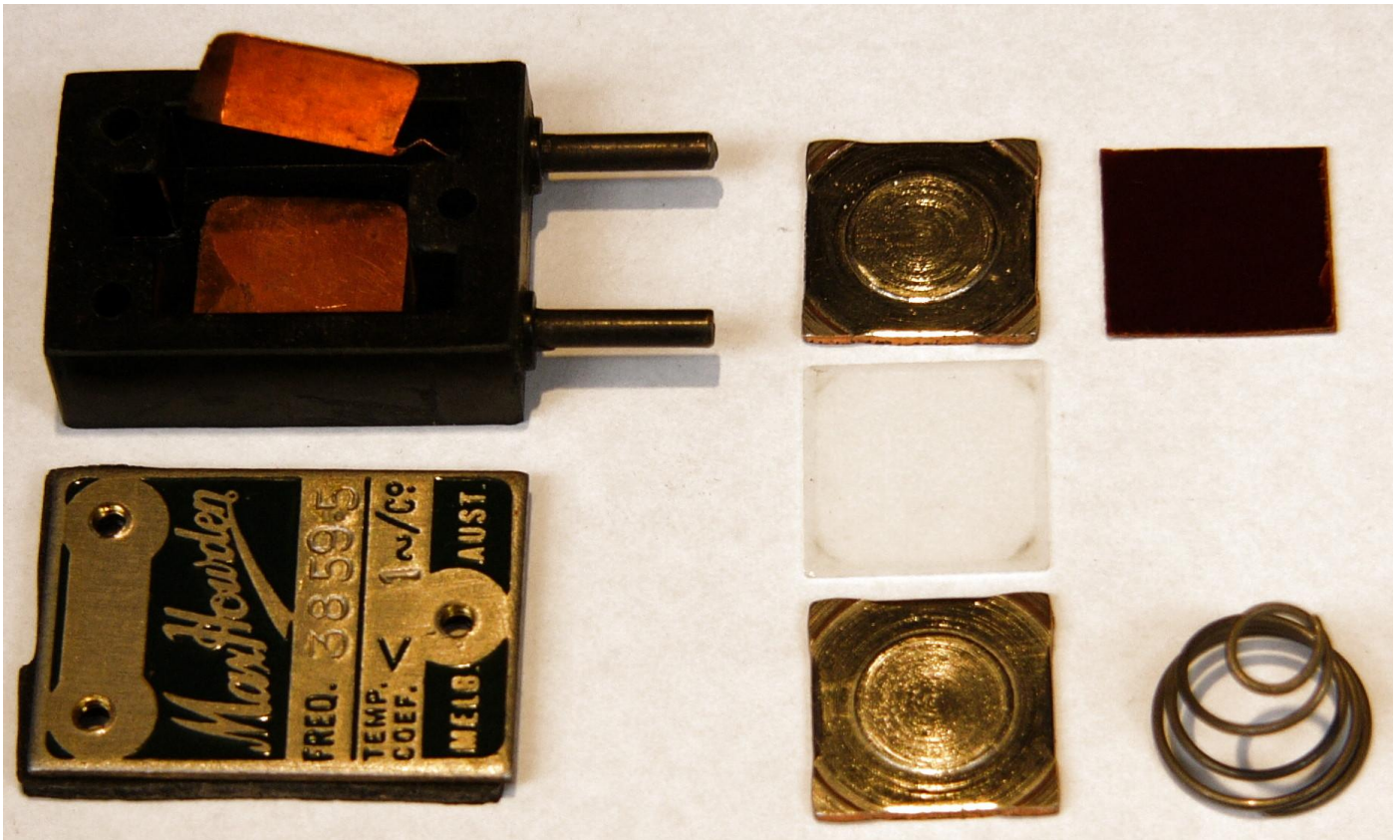

Although the crystal has electro-mechanical resonance it's resonant action can be represented by an electrical resonance circuit, as shown in fig. (b). The crystal actually behaves as a series R-L-C circuit in parallel with CM where CM is the capacitance of the mounting electrodes (stray capacitance). Because the crystal losses, represented by R, are small the equivalent crystal Q is high-typically 20,000. Values of Q up to 106 can be obtained from crystals in actual circuit. Because of presence of CM, the crystal has two resonant frequencies. One of these is the **series resonant** frequency and the crystal **impedance is very low**. The other is **parallel resonant** frequency F_p which is due to parallel resonance of capacitance CM and the reactance of the series circuit. In this case **crystal impedance is very high**. The impedance versus frequency curve of the crystal is shown in the figure below. In order to use the crystal properly it must be connected in a circuit so that its low impedance in the series-resonant operating mode or high impedance in the anti-resonant or parallel resonant operating mode is selected.

The two frequencies are very close to each other. It is due to the fact that the ratio C/CM is very small. To stabilize the frequency of an oscillator, a crystal may be operated at either its series or parallel resonant frequency.

Crystal Oscillator Circuits – Page 4

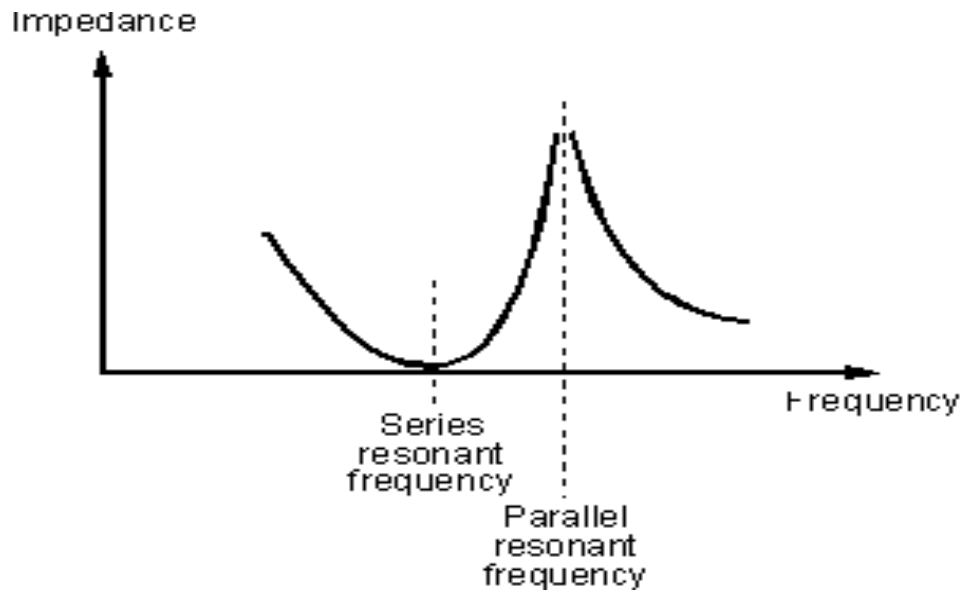

Colpitts Quartz Crystal Oscillator

Crystal oscillator circuits are generally constructed using bipolar transistors or FETs. This is because although operational amplifiers can be used in many different low frequency ($\leq 100\text{kHz}$) oscillator circuits, operational amplifiers just do not have the bandwidth to operate successfully at the higher frequencies suited to crystals above 1MHz.

The design of a **Crystal Oscillator** is very similar to the design of the L and C Colpitts Oscillator except that the LC tank circuit that provides the feedback oscillations has been replaced by a quartz crystal as shown below.

Colpitts Crystal Oscillator

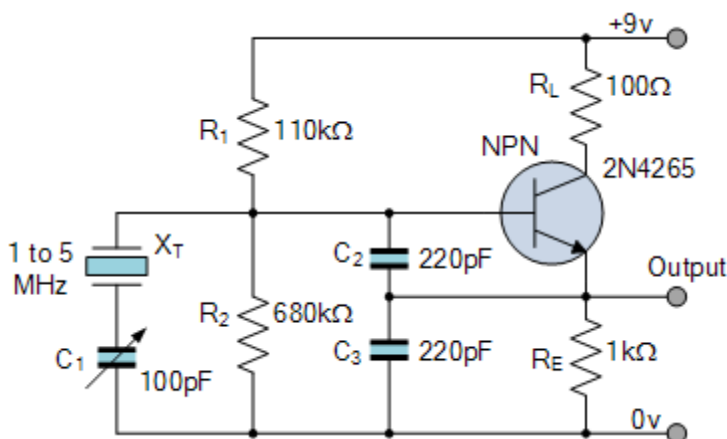

This type of **Crystal Oscillators** are designed around a common collector (emitter-follower) amplifier. The R_1 and R_2 resistor network sets the DC bias level on the Base while emitter resistor R_E sets the output voltage level. Resistor R_2 is set as large as possible to prevent loading to the parallel connected crystal. This is a **parallel resonant circuit**.

Transistors like 2N2222 and 2N3904 work well in this circuit.

Crystal Oscillator Circuits – Page 5

Any general purpose NPN transistor can be used so long as it has an FT of above 100Mhz, well above the crystals fundamental frequency which is usually be between about 5MHz and 25MHz.

The circuit diagram above of the **Colpitts Crystal Oscillator** circuit shows that capacitors, C1 and C2 shunt the output of the transistor which reduces the feedback signal. Therefore, the gain of the transistor limits the maximum values of C1 and C2. The output amplitude should be kept low in order to avoid excessive power dissipation in the crystal otherwise could destroy itself by excessive vibration.

Another Colpitts Oscillator circuit.

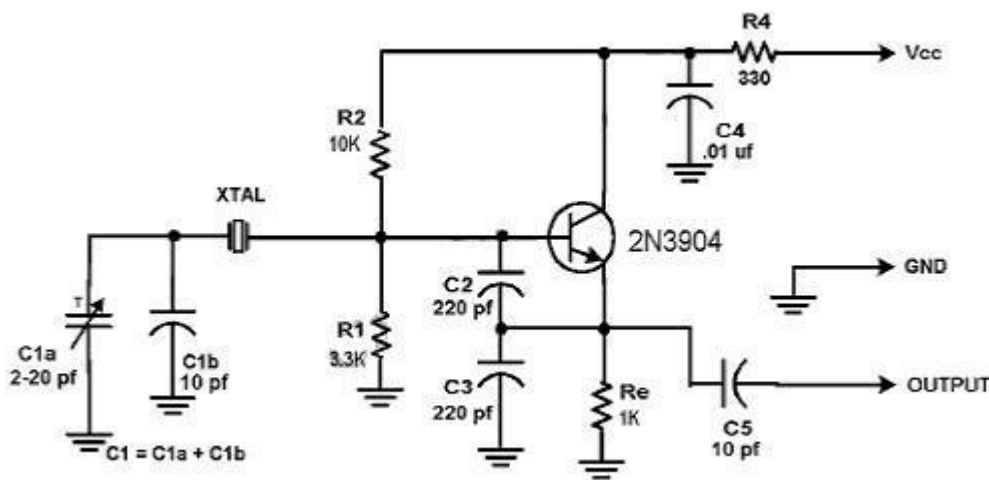

In this circuit, the crystal acts as an inductance. A large value capacitive divider is used between gate, source, and ground, and a small series capacitor is placed in the crystal circuit. You should choose the components values so that? C2 C3 to C1? ratio has the highest possible value. The ratio of 5 to 10 to 1 is usually used.? The schematic shows the typical values. This circuit introduce a little loading on the crystal. The relatively high values of C2 and C3 “swamp out” variations and drift caused by variations in device characteristics. Frequency can be fine tuned with C1. A clean enough sine wave appears at the emitter of the transistor.

Pierce Oscillator

Another common design of the quartz crystal oscillator is that of the **Pierce Oscillator**. The Pierce oscillator is very similar in design to the previous Colpitts oscillator and is well suited for implementing crystal oscillator circuits using a crystal as part of its feedback circuit.

The Pierce oscillator is primarily a **series resonant tuned circuit** (unlike the parallel resonant circuit of the Colpitts oscillator) which uses a JFET for its main amplifying device as FET's provide very high input impedances with the crystal connected between the Drain and Gate via capacitor C1 as shown below.

Crystal Oscillator Circuits – Page 6

Pierce Crystal Oscillator

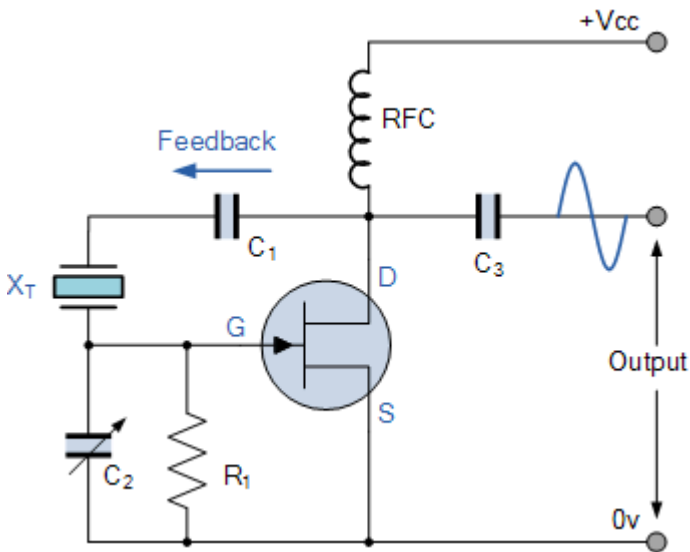

In this simple circuit, the crystal determines the frequency of oscillations and operates at its series resonant frequency, f_s giving a low impedance path between the output and the input. There is a 180° phase shift at resonance, making the feedback positive. The amplitude of the output sine wave is limited to the maximum voltage range at the Drain terminal.

Resistor, R_1 controls the amount of feedback and crystal drive while the voltage across the radio frequency choke, RFC reverses during each cycle. Most digital clocks, watches and timers use a Pierce Oscillator in some form or other as it can be implemented using the minimum of components.

Variations in supply voltage, transistor parameters, etc. have no effect on the circuit operating frequency which is held stabilised by the crystal. The circuit frequency stability is set by the crystal frequency stability, which is good. For greater stability, the crystal may be placed in a temperature controlled oven.

OVERTONE CRYSTAL OSCILLATOR

Crystals with an operating frequency of over about 45MHz have been very difficult to achieve because of their very small size. This is overcome by using overtone circuits.

In these circuits the output frequency is three or five times the “cut frequency” of the crystal. This is achieved by having a tuned circuit in the output, tuned to the desired frequency.

This oscillator is designed for overtone crystals, the actual output frequency of the circuit in the 20-100 MHz range operating in the third and fifth mode. Operating frequency is determined by the tuned circuit. Higher order harmonics can be selected to achieve even higher output frequencies.

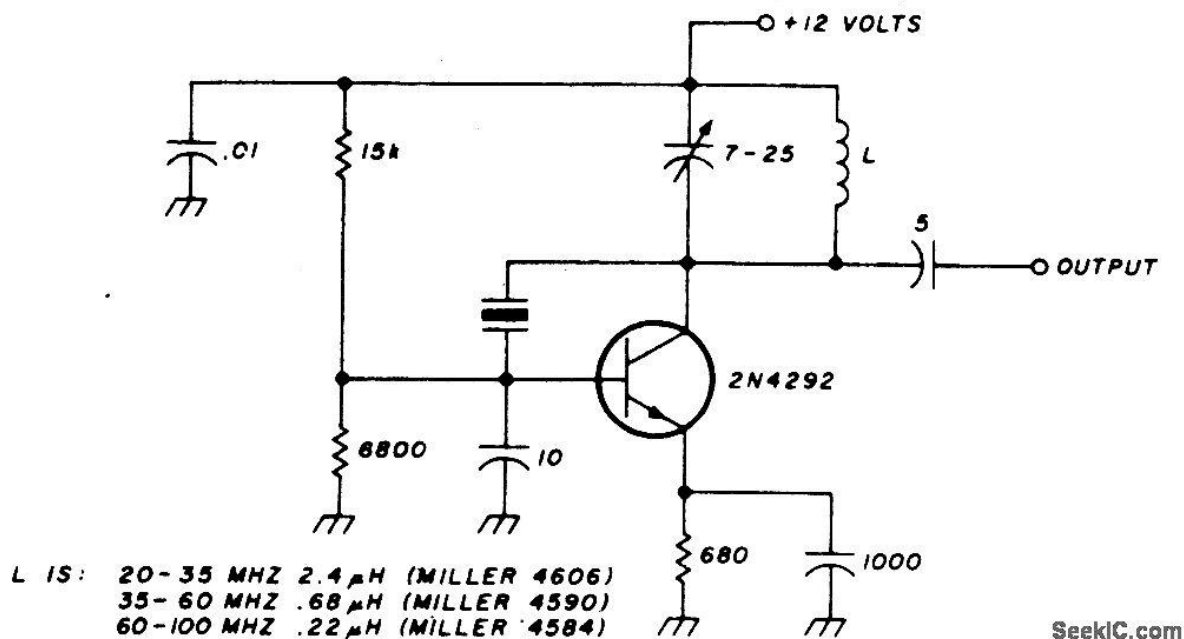

Precautions when “driving” crystals

Crystal oscillators must be designed to provide a load capacitance on the crystal as per specifications listed by the manufacturer. This requirement is essential for obtaining oscillations at the specified frequency. It is also important from the point of view of limiting the power supplied to the crystal to the specified maximum. Too much crystal power causes distortion in the oscillator waveform. It also causes overheating of the crystal, consequently rendering the resonant frequency unstable. More important is that the thin-plated electrodes may be melted off an overdriven crystal, destroying the device. Typical maximum drive levels for plated crystals varies from 2 m W to 10 m W.

The maximum permissible drive power limits the ac voltages that may be applied across the crystal and consequently affects the design of oscillator circuits. Crystal manufacturers usually specify the resistance of individual crystal, as well as maximum drive power. From these two, the maximum crystal ac voltage may be determined by using the relation $P = V^2/R$.

Modern small crystals do not usually survive in old style tube oscillator circuits, the drive power is too great and will destroy the crystal very quickly.

Altering the operating frequency

The operating frequency of crystal oscillator can be “pulled or pushed” a very small amount by the use of series or parallel capacitors and or inductors. A capacitor in series will pull the frequency high and a capacitor in parallel will push the frequency low but this is very hard to achieve.

Crystal Oscillator Circuits – Page 8

CMOS Crystal Oscillator

As well as using transistors and FETs, we can also create a simple basic parallel-resonant crystal oscillator similar in operation to the Pierce oscillator by using a CMOS inverter as the gain element. The basic quartz crystal oscillator consists of a single inverting Schmitt trigger logic gate such as the TTL 74HC19 or the CMOS 40106, 4049 types, an inductive crystal and two capacitors. These two capacitors determine the value of the crystals load capacitance. The series resistor helps limit the drive current in the crystal and also isolates the inverters output from the complex impedance formed by capacitor-crystal network.

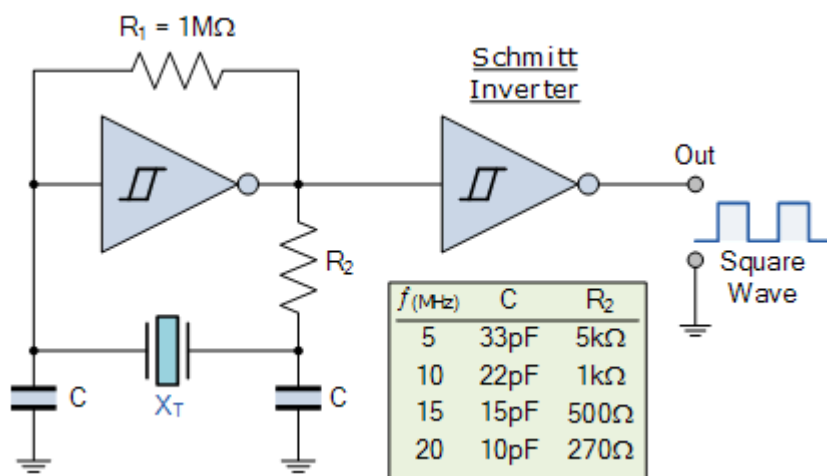

The crystal oscillates at its series resonance frequency. The CMOS inverter is initially biased into the middle of its operating region by the feedback resistor, R_1 . This ensures that the Q-point of the inverter is in a region of high gain. Here a $1\text{M}\Omega$ value resistor is used, but its value is not critical as long as it is more than $1\text{M}\Omega$. An additional inverter is used to buffer the output from the oscillator to the connected load.

The inverter provides 180° of phase shift and the crystal capacitor network the additional 180° required for oscillation. The advantage of the CMOS crystal oscillator is that it will always automatically readjust itself to maintain this 360° phase shift for oscillation.

Unlike the previous transistor based crystal oscillators which produced a sinusoidal output waveform, as the CMOS Inverter oscillator uses digital logic gates, the output is a square wave oscillating between HIGH and LOW. Naturally, the maximum operating frequency depends upon the switching characteristics of the logic gate used.

Crystal housings

There have been many different housing used to contain crystals used over the years. During the Second World War millions of FT-243 crystals were produced and these were also extensively used in post War Amateur Radio and two way radio equipment. Here are just a few of the common crystal housing in use today.

Crystal Oscillator Circuits – Page 9

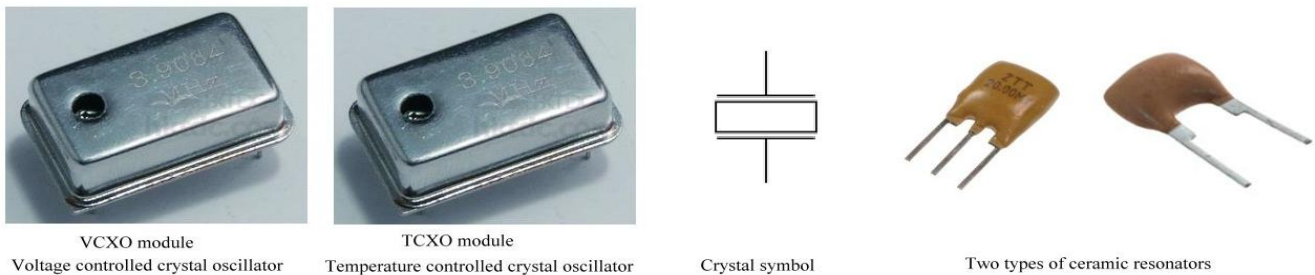
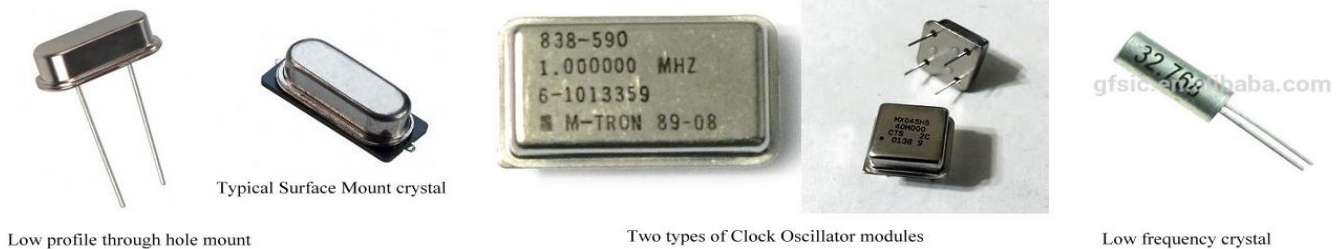

What frequency is written on a crystal ?

Firstly there is often no indication of the mode of operation or the loading capacitance. To make matters worse, many crystals that were used in CB and early Amateur Radio transceivers had the transmit and receive frequency written on them, not the actual oscillating frequency. This was because the local oscillator had to operate at a frequency displaced by the Intermediate Stages frequency. In simple equipment this was usually 455KHz but could have been a much higher frequency, particularly in Amateur radio rigs.

Another factor is these are usually over tone crystals and when tested in a simple crystal tester they will produce their fundamental frequency, not the overtone frequency.

And now for some more technical stuff adapted from - <http://www.us-electronics.com/files/crystals.pdf>

Quartz is a crystalline form of silicon dioxide (SiO₂) which is abundant in nature, forming about 12% of the Earth's crust. A combination of the limited supply of natural quartz along

Crystal Oscillator Circuits – Page 10

with its high cost has resulted in the development of cultured quartz. Crystals of quartz are grown by dissolving SiO₂ in an alkaline solution at high temperature and pressure. This process takes place in auto cleaves which are built to withstand the extreme conditions required. Seed crystals are mounted in frames in the cooler part of the autoclave whilst a solution of sodium carbonate or hydroxide and fragments of SiO₂ are placed in the warmer portion. The solution moves from the hotter to the cooler region and in doing so, dissolves the nutrient and deposits on the seed crystal. Temperatures are controlled throughout this process.

Large bars of crystal can be grown in about ten weeks. The quality of the quartz depends on the conditions of growth. Crystals are grown in shapes and sizes that minimize wastage of time and material. The bars of crystal are cut into wafers. The angle at which these wafers are cut is crucial in determining the frequency and temperature stability of the final crystal. The most common cut is the AT-cut where the blank is cut from the bar of crystal at approximately 35°, allowing a frequency range of 1MHz to 300MHz.

Since the discovery of the piezoelectric properties of quartz in 1880 by Pierre Curie, quartz has become a significant factor in the growth of the electronics industry. By stretching or compressing a piezoelectric material a voltage is generated. The reverse is also true: a voltage applied to the material causes it to become mechanically stressed. In the case of crystals, the pressure resulting from a voltage being applied is displayed in the form of oscillations at a particular resonant frequency.

The frequency is a function of the thickness of the crystal. By carefully preparing a crystal, it can be made to oscillate at any frequency. The lowest frequency is called the fundamental frequency and can be supplied up to about 45MHz. Higher frequencies (to over 300 MHz) are achieved by operating the crystal at odd overtones (harmonics); 3rd, 5th, 7th, 9th and 11th and tuning the output circuit with an L/C tuned circuit so that the crystal oscillates at its designed overtone frequency.

Overtone crystals are specially processed for plane parallelism and surface finish in order to enhance their performance at the required overtone frequency. The overtone frequency is higher than the equivalent harmonic multiple of the fundamental by approximately 25KHz per overtone.

Vibration modes

The quartz crystal can vibrate in several different ways, and this means that it has several resonances, all on different frequencies. Fortunately the way in which the quartz crystal blank is cut from the original crystal itself can very significantly reduce this. In fact the angle of the faces relative to the original crystal axes determines many of its properties from the way it vibrates to its activity, Q, and its temperature co-efficient. There are three main ways in which a crystal can vibrate: longitudinal mode, low frequency face shear mode, and high frequency shear. A cut known as the AT cut used for most crystals used in traditional radio and electronics circuits uses the high frequency shear mode.

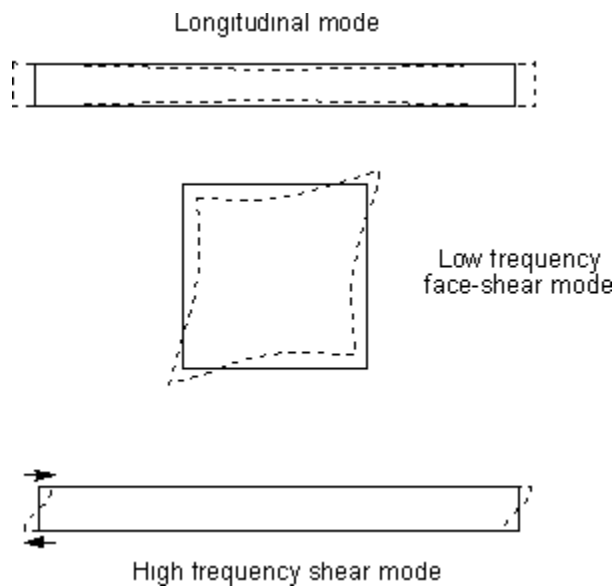

Vibrational modes of a quartz crystal resonator

(For the sake of clarity, the movements have been greatly exaggerated)

You can find detail of how to build a simple crystal tester on my web site at:

<http://www.philipstorr.id.au/radio/seven/projects2014.htm>

You will need a frequency counter or a modern digital Oscilloscope that has a frequency readout. If you do not need exact accuracy you could use a communications receiver.

This document will be on my web site at:

<http://www.philipstorr.id.au/radio/technical/technical.htm>

Document - Crystal Techo.pdf by Phil, VK5SRP 26/01/2017